

MODIFICACIONES		
ERA	ES	FECHA

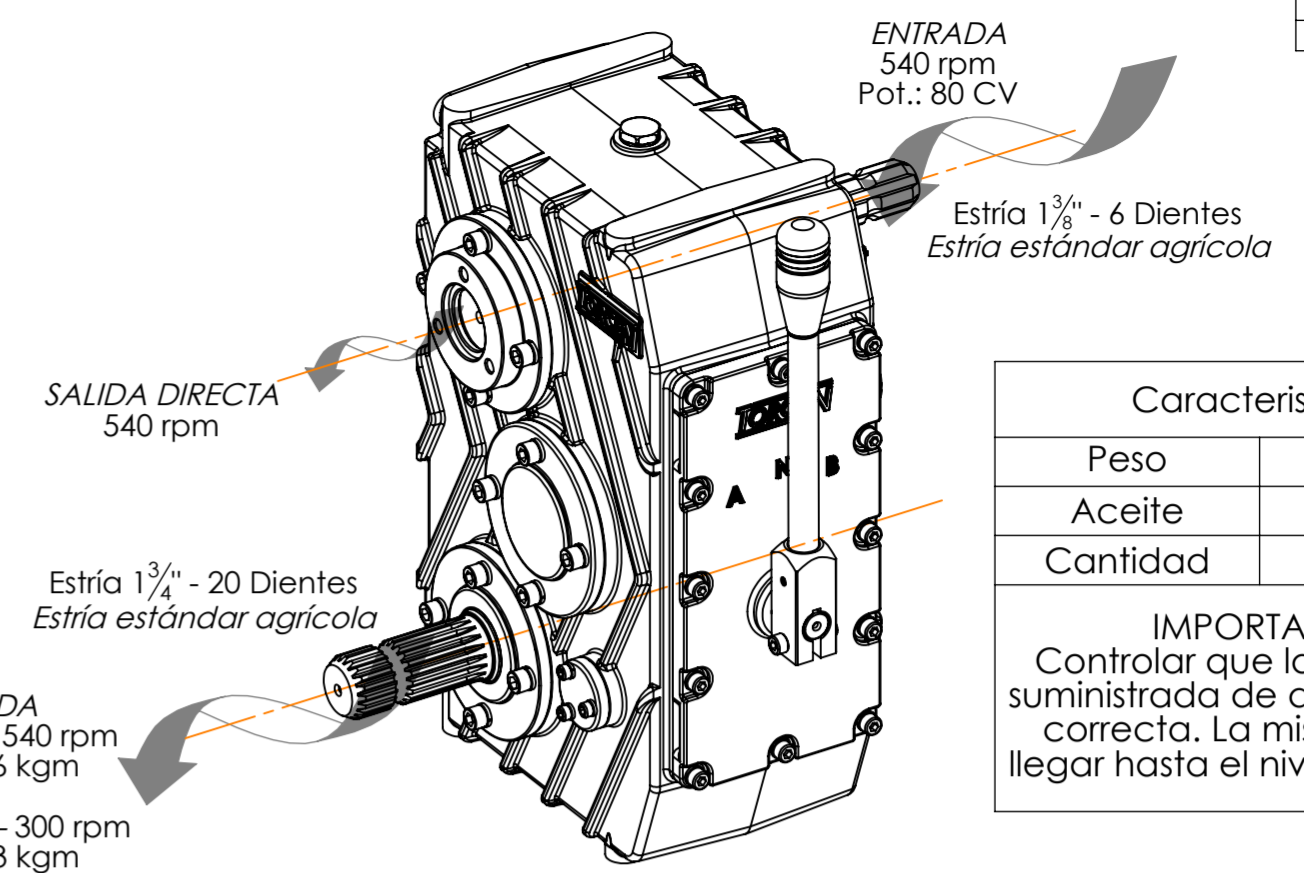

Características	
Peso	80 kg
Aceite	SAE 90 EP
Cantidad	± 8 litros

**IMPORTANTE**  
Controlar que la cantidad suministrada de aceite sea la correcta. La misma debe llegar hasta el nivel indicado.

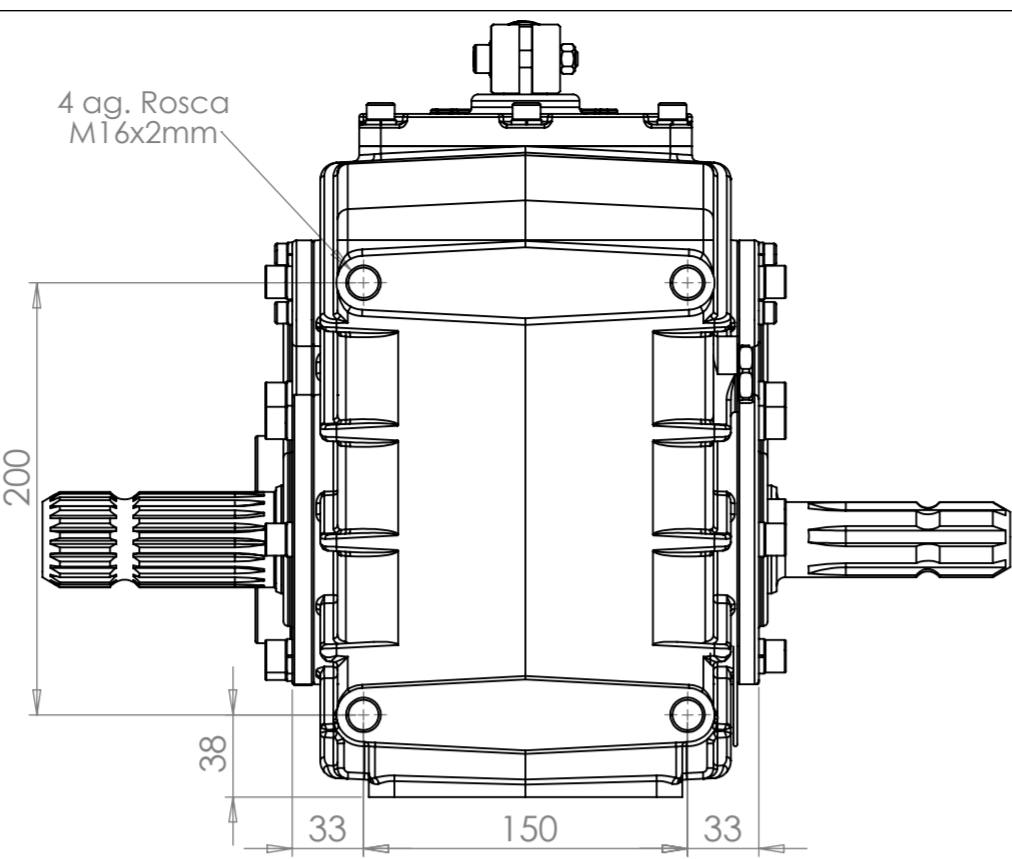
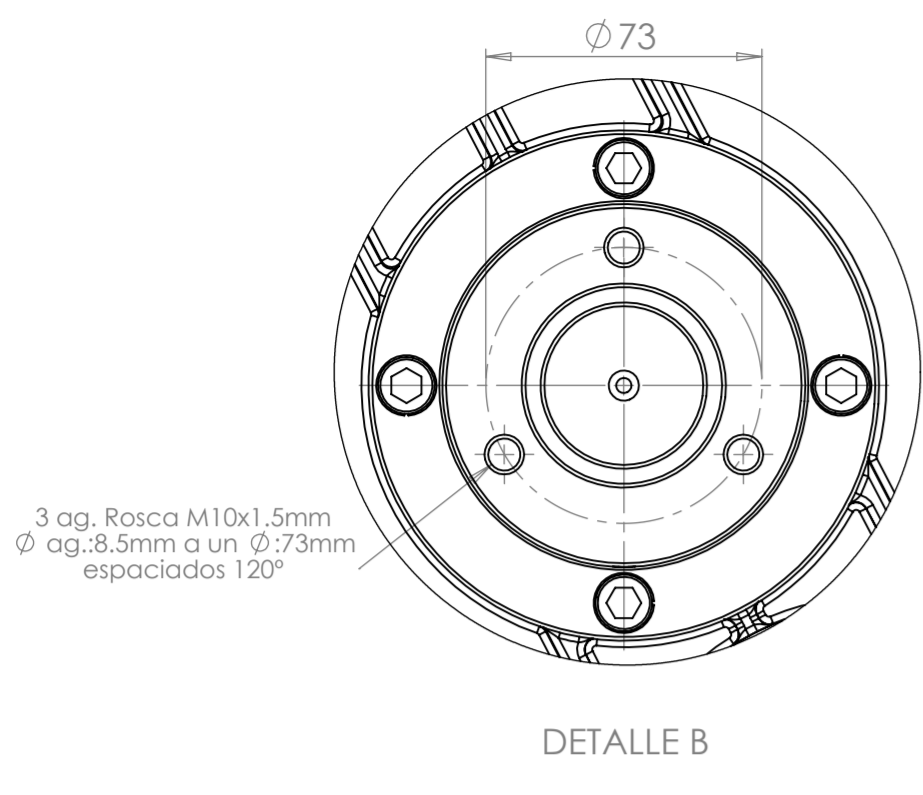
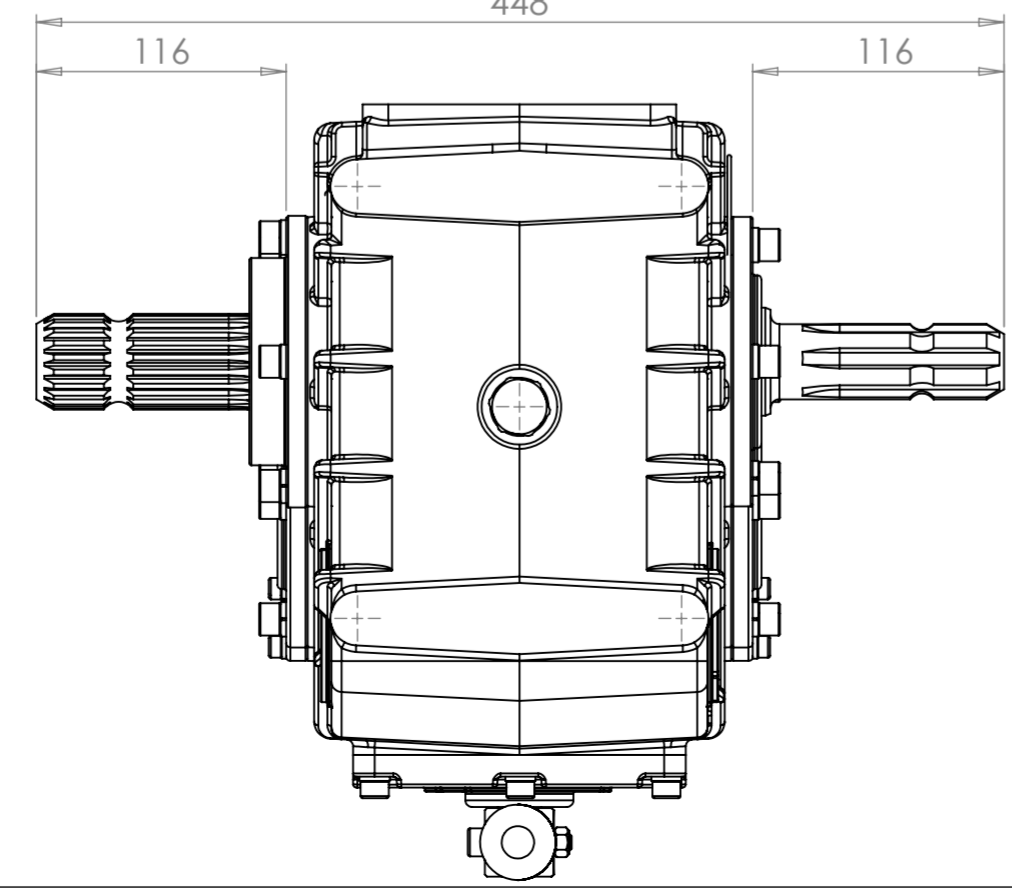
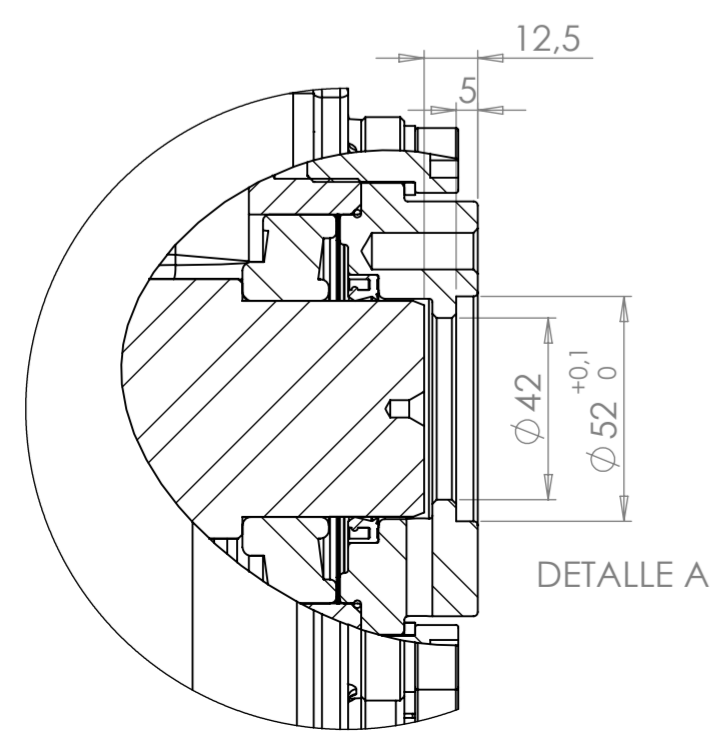
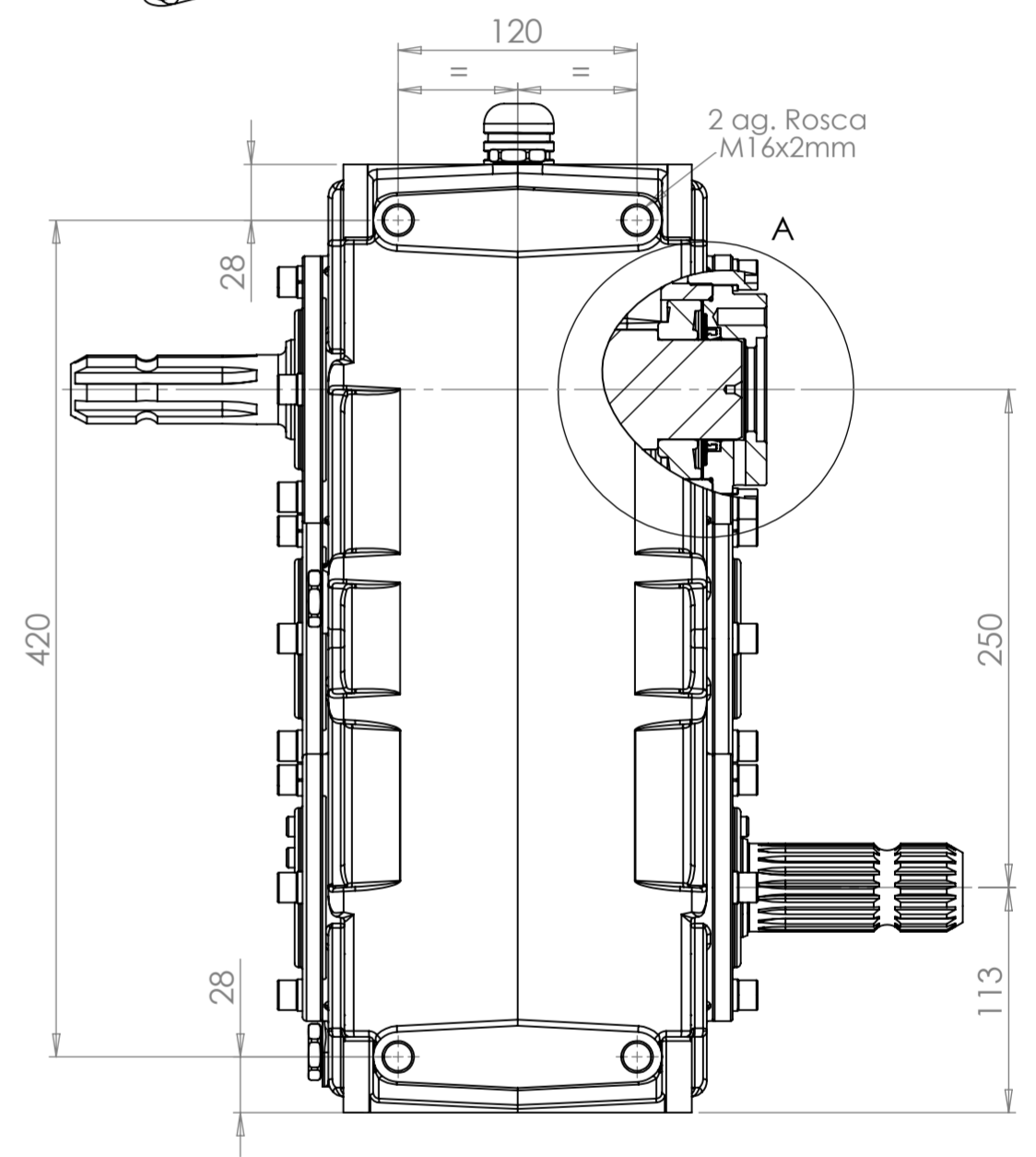
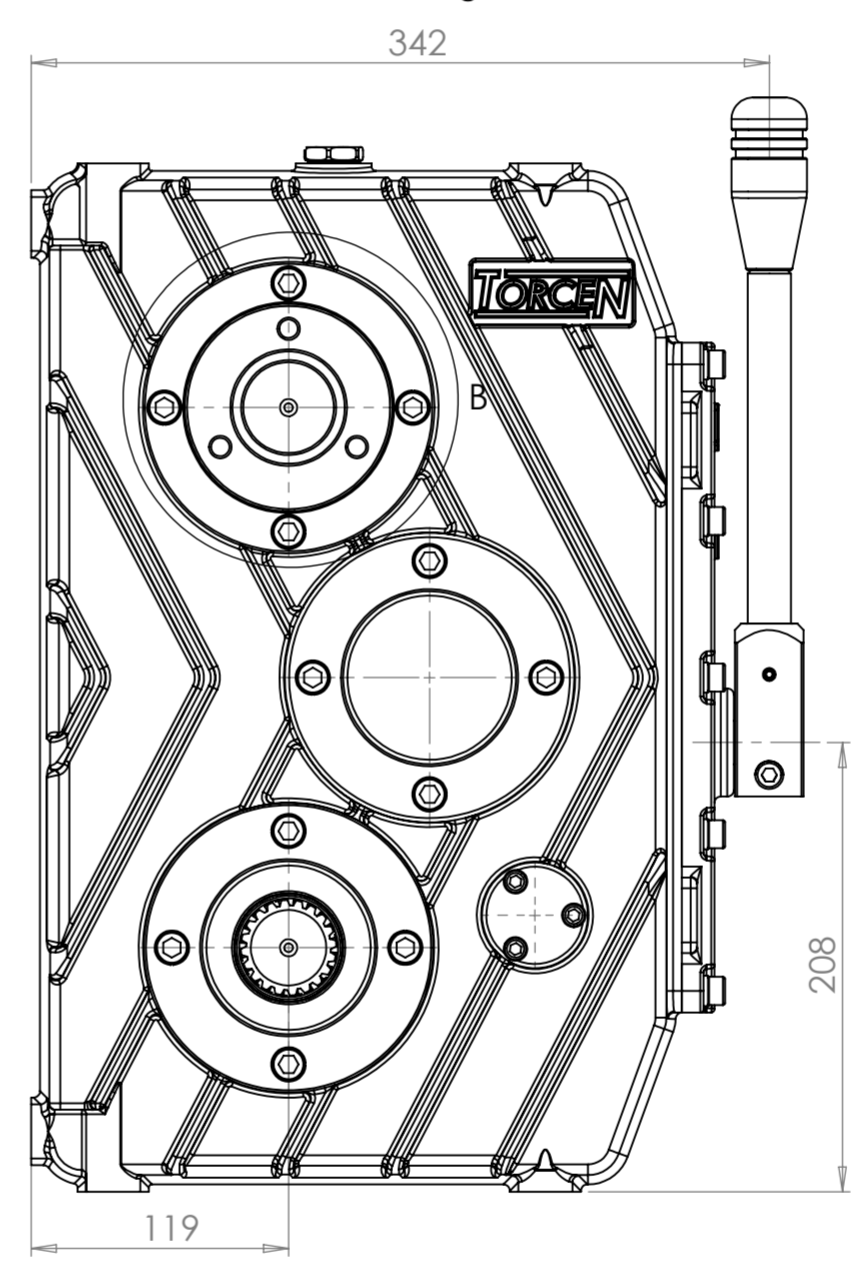
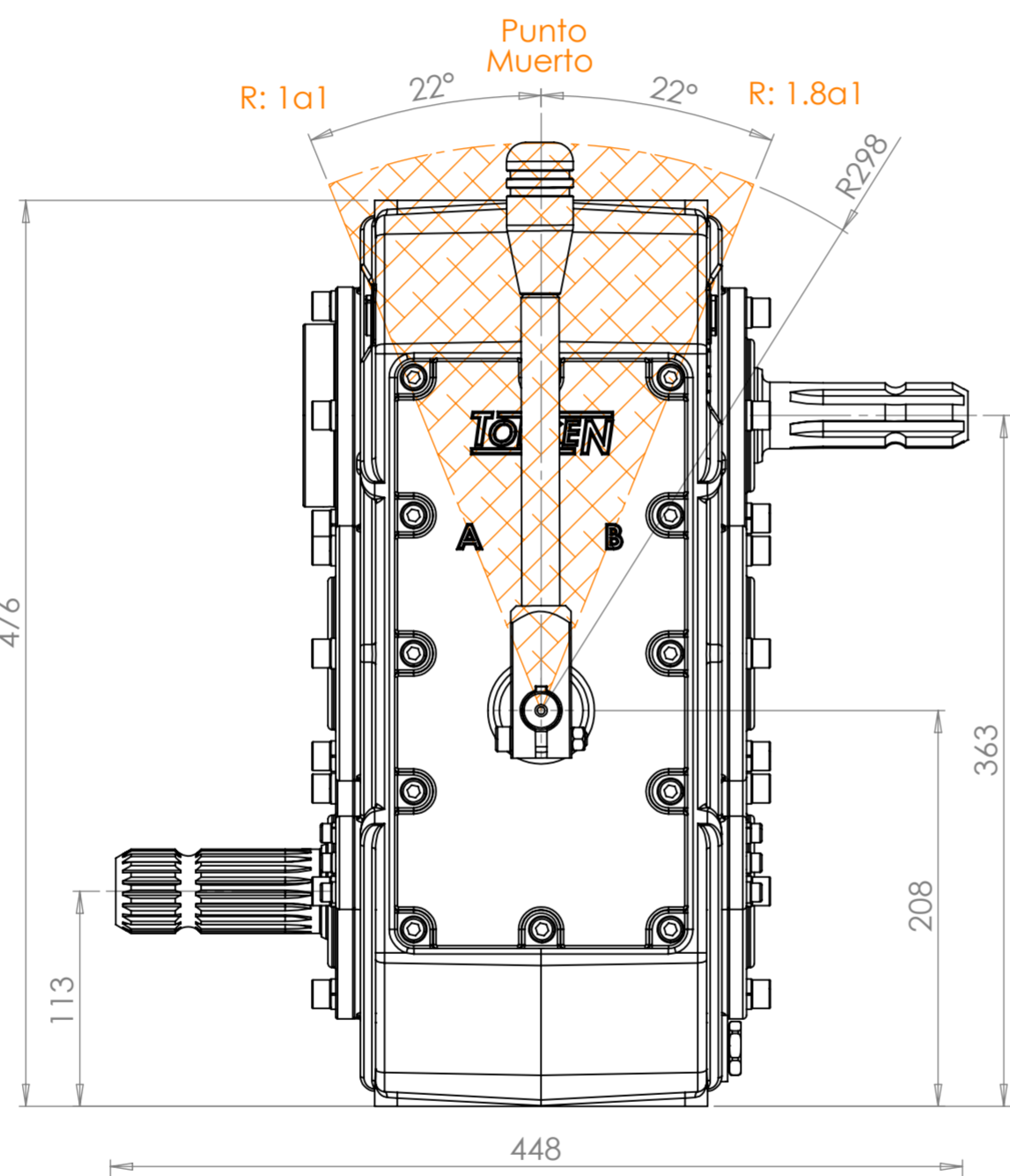
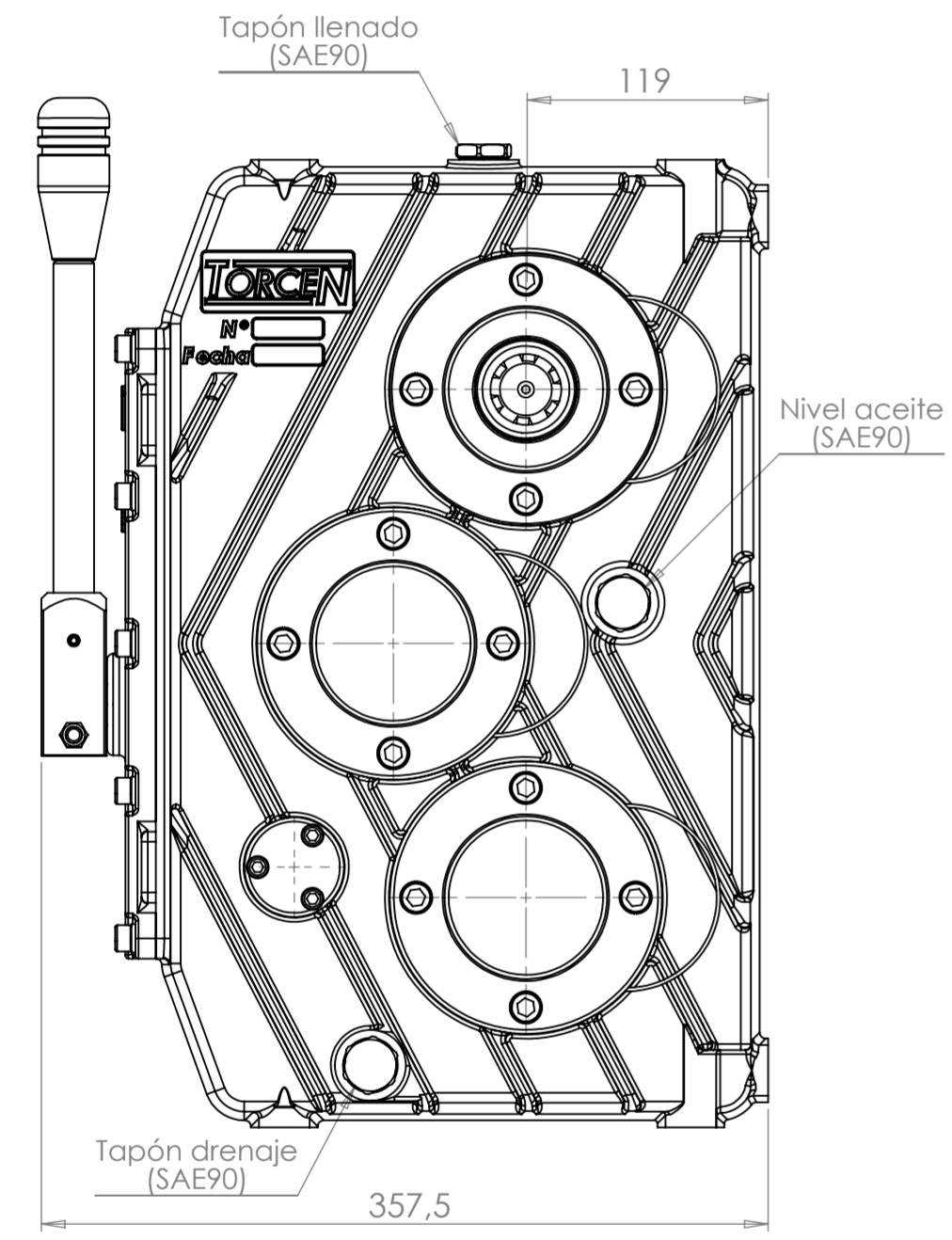

TOLERANCIAS NO INDICADAS SEGÚN DIN 7168										
Dimensiones	de 0,3	> 3	> 6	> 30	> 120	> 400	> 1000	> 2000	> 4000	> 10000
FFd (mecanizada)	± 0,05	± 0,05	± 0,1	± 0,15	± 0,20	± 0,30	± 0,5	± 0,8	-	-
Basta	-	± 0,5	± 1,0	± 1,5	± 2,0	± 3,0	± 4,0	± 6,0	± 8,0	± 10,0

Observación Al menos otras indicaciones las dimensiones son expresadas en milímetros	Cant: 1	Fecha	Nombre	Firma	Plano N°	
	Dib.	05/05/15	Ing. Marino E.		1 35 00 000	
	Rev.				Peso: Kg.	
	Apr.					
	Esc. 1:5	Material	Provisión			
	Denominación: Caja T80-2V				Equipo	
	A2				Revisión 00	